



Freshbox E-100 ERV black

Single-room air handling units

- Power of electrical preheater: 700
- Heat exchanger type: Counter flow
- Heat exchanger material: Enthalpy
- Sound-insulated casing
- Enthalpy heat exchanger
- Bypass: Auto
- Preheater: Electric
- Control: Built-in control panel, Wired control panel, Remote Control
- Casing material: Coated steel
- Temperature sensor: Built-in

	Unit of measurement	Freshbox E-100 ERV black		
Phases	-	1		
Minimum supply voltage	V	230		
Maximum supply voltage	V	230		
Power supply frequency	Hz	50/60		
Power of electrical preheater	W	700		
Heat recovery efficiency	%	90	86	83
Heat recovery efficiency, max	%	90		
Heat exchanger type	-	Counter flow		
Heat exchanger material	-	Enthalpy		
Weight	kg	31		
Transported air temperature (max)	°C	40		
Transported air temperature (min)	°C	-20		
Ambient air temperature min	°C	1		
Ambient air temperature max	°C	40		
Ambient air humidity max	%	70		
Ingress protection rating	-	IP22		
Ingress protection rating of the drive	-	IP44		

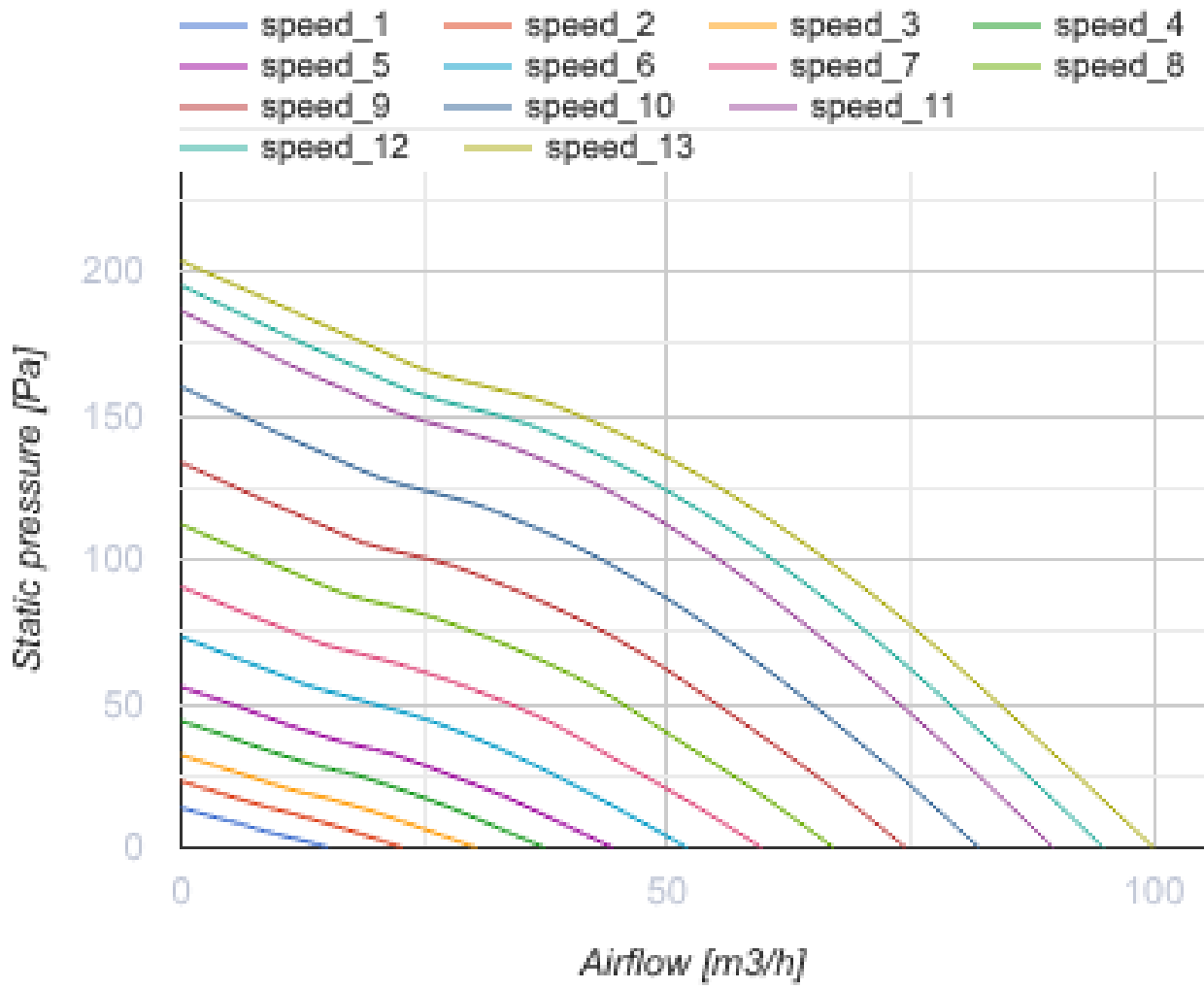

Dimensions

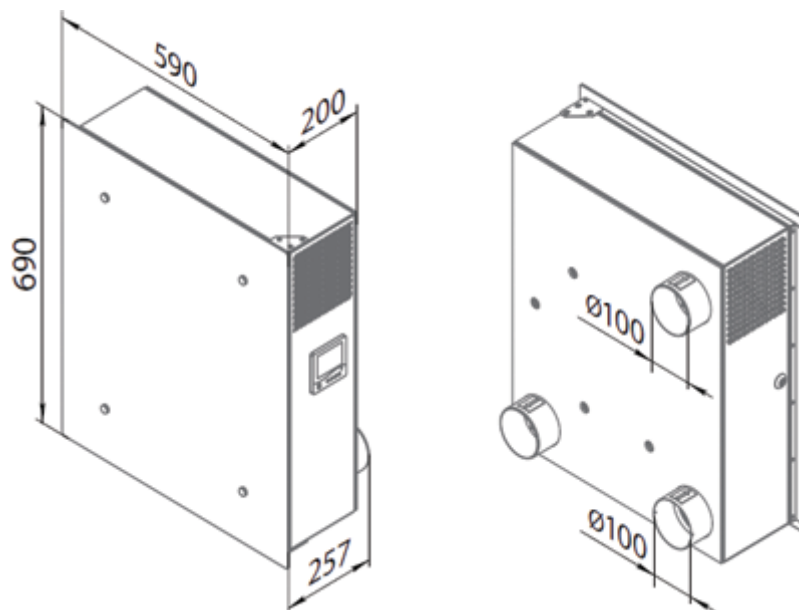

Accessories

CO2 sensors

Name	Photo	Description
CD-1		CO2 sensors
CD-2		CO2 sensors

Other accessories

Name	Photo	Description
EH Freshbox 100		Electric heater